

PPAC-16

PCB Terminal Blocks > Panel Feed-Through Blocks

Date:2026-04-06Version:1.2

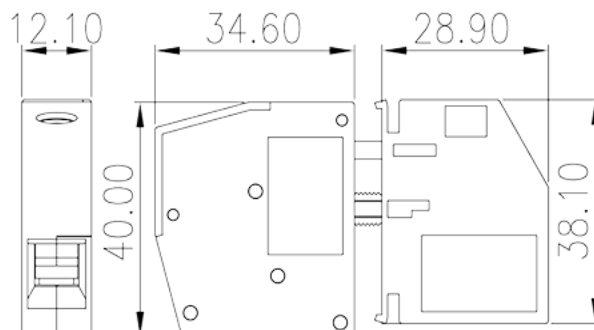
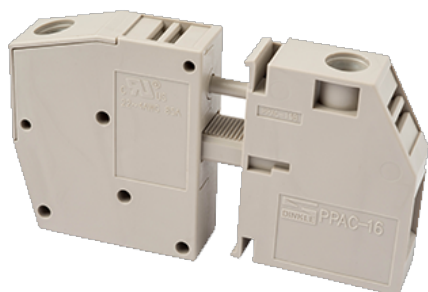

The web catalog is for reference only. Dinkle remains the right of product modification and engineering change of the design. The final product is made according to engineering drawing.

Product Description

M5, 600V, 85A

General information

Short description	Panel Feed-Through, Screw Connection
Category	Panel Feed-Through
Color	Grey (default)
Connection method	Screw connection
Type of locking	Without
Length (mm)	12.1
Width (mm)	34.6+28.9
Height (mm)	40.4
Number of positions	1P

Material information

Insulation material	PA
Insulation material group	I
Flame retardant rating , compliant with UL94	V0
Insulation resistance	□500MΩ at DC 500V
Conductor material	COPPER ALLOY

Plating of conductor surface

Tin PLATED

Connection data-IEC

Rated voltage (V)	500
Rated current (A)	101
Rated voltage (III/3)(V)	500
Rated impulse voltage (III/3)(KV)	6
Conductor cross section solid. min (mm ²)	0.5
Conductor cross section solid.max (mm ²)	25
Conductor cross section stranded. min (mm ²)	0.5
Conductor cross section stranded. max (mm ²)	16
Conductor cross section flexible, with min ferrule without plastic sleeve (mm ²)	0.5
Conductor cross section flexible, with max ferrule without plastic sleeve (mm ²)	16
Conductor cross section flexible, with min ferrule with plastic sleeve (mm ²)	0.5
Conductor cross section flexible, with max ferrule with plastic sleeve (mm ²)	16
2 conductors with same cross section, solid, min (mm ²)	0.5
2 conductors with same cross section, solid, max (mm ²)	10
2 conductors with same cross section, stranded, min (mm ²)	0.5
2 conductors with same cross section, stranded, max (mm ²)	6
2 conductors with same cross section flexible, with min ferrule without plastic sleeve (mm ²)	0.5
2 conductors with same cross section flexible, with max ferrule without plastic sleeve (mm ²)	6
2 conductors with same cross section flexible, min twin ferrules with plastic sleeve (mm ²)	0.5
2 conductors with same cross section flexible, max twin ferrules with plastic sleeve (mm ²)	10
Screw thread	M5
Philips screwdriver size	PZ2
Rated torque (N.m)	2.0~2.3
Recommend tightening torque. min (N.m)	2
Recommend tightening torque. max (N.m)	3.4
Stripping Length (mm)	16~17

Connection data-UL

Rated voltage (UL/CUL Group B)(V)	600
Rated current (UL/CUL Group B)(A)	85
Rated voltage (UL/CUL Group C)(V)	600
Rated current (UL/CUL Group C)(A)	85
Min. solid wire connection (AWG) acc. to UL/CUL	22
Max. solid wire connection AWG acc. to UL/CUL	4
Min. stranded wire connection AWG acc. to UL/CUL	22
Max. stranded wire connection AWG acc. to UL/CUL	4

Environment & Safety

Back of the hand protection (YES or NO)	YES
Finger protection (YES or NO)	YES
Operating temperature. max (°C)	120
Operating temperature. min (°C)	-40

UL Recognized

Wire Range (Group B)(AWG)	22~4
Rated voltage (Group B)(V)	600
Rated current (Group B)(A)	85
Wire Range (Group C)(AWG)	22~4
Rated voltage (Group C)(V)	600
Rated current (Group C)(A)	85

CUL Recognized

Wire Range (Group B)(AWG)	22~4
Rated voltage (Group B)(V)	600
Rated current (Group B)(A)	85
Wire Range (Group C)(AWG)	22~4
Rated voltage (Group C)(V)	600
Rated current (Group C)(A)	85

Drawings

--	--

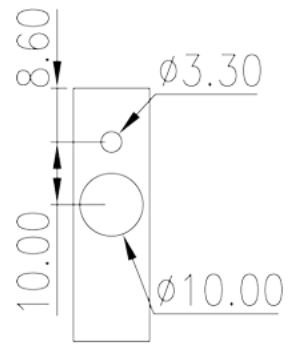
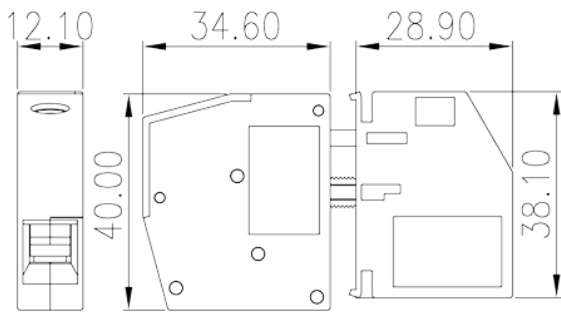

Approvals

